



National Research  
Council Canada

Conseil national  
de recherches Canada

Institute for  
Research in  
Construction

Institut de  
recherche en  
construction

**CCMC 12966-R**

**CCMC**

*EVALUATION  
REPORT*

DIVISION	03131
Issued	2000-03-29
Re-evaluated	2004-05-05
Revised	2004-07-29
Re-evaluation due	2006-03-29

## ***ECO-Block®***

ECO-Block, LLC  
11220 Grader Street, Suite 700  
Dallas, Texas  
75238, U.S.A.

Tel.: (214) 503-1644  
(800) 595-0820  
Fax: (214) 503-0321  
Web Site: [www.eco-block.com](http://www.eco-block.com)

Plant: POLYMOS Inc.  
150, 5<sup>e</sup> boulevard  
Terrasse-Vaudreuil (Québec)

*This Report contains no endorsement, warranty, or guarantee, expressed or implied, on the part of the National Research Council of Canada for any evaluated material, product, system or service described herein. NRC accepts no responsibility for the performance of any product described herein if manufactured and/or used outside the purpose of the CCMC evaluation. Readers should not infer that NRC has evaluated the product for any purpose or characteristic other than stated herein.*

### ***1. Purpose of Evaluation***

The proponent sought confirmation from the Canadian Construction Materials Centre (CCMC) that “ECO-Block®” can serve as a wall forming system, resulting in a monolithic concrete wall in compliance with the intent of the National Building Code of Canada (NBC) 1995.

### ***2. Opinion***

Subject to the limitations and conditions stated in this report, test results and assessments provided by the proponent show that “ECO-Block®” complies with CCMC’s Technical Guide for Modular, Expanded Polystyrene or Polyurethane Concrete Forms, Masterformat Number 03133, dated 94-10-11, and provides a level of performance equivalent to that required in:

- NBC 1995, Article 4.3.3.1., Subsection 9.3.1. and Section 9.4.

Ruling No. 04-12-116 (12966-R) authorizing the use of this product in Ontario, subject to the terms and conditions contained in the Ruling, was made by the Minister of Municipal Affairs and Housing on

15 June, 2004 pursuant to s.29 of the Building Code Act, 1992 (see Ruling for terms and conditions).

Canada Mortgage and Housing Corporation permits the use of this product in construction financed or insured under the *National Housing Act*.

Note: The attachment of exterior cladding and interior finishing materials has not been assessed by the present evaluation.

### 3. Description

“ECO-Block®” is a modular, interlocking concrete form system consisting of two expanded polystyrene (EPS) insulation panels that have a series of equally-spaced polypropylene plastic webs molded into the polystyrene.

The EPS face panels are connected on site with a series of polypropylene connector ties of varying length. The EPS face panels have a preformed interlocking design along their top and bottom edges to facilitate stacking and alignment, as well as to prevent freshly-laced concrete from leaking.

The forms are dry-laid and stacked in a running (staggered) configuration. The laid-up units form a rectangular space that, once filled with concrete, forms an insulated, monolithic concrete wall of uniform thickness.

Reinforcement shall be added where strength requirements for above or below-grade loadbearing walls, beams, lintels and shear walls require it.

The EPS insulation panels that form the faces of the units have external dimensions of 1219 mm in length, 406 mm in height and 63 mm in thickness. The polypropylene plastic ties are available in three lengths to produce 100 mm, 150 mm and 200 mm-wide concrete walls.

The units are illustrated in Figure 1.

Typical details for residential construction are shown in figures 2, 3 and 4.

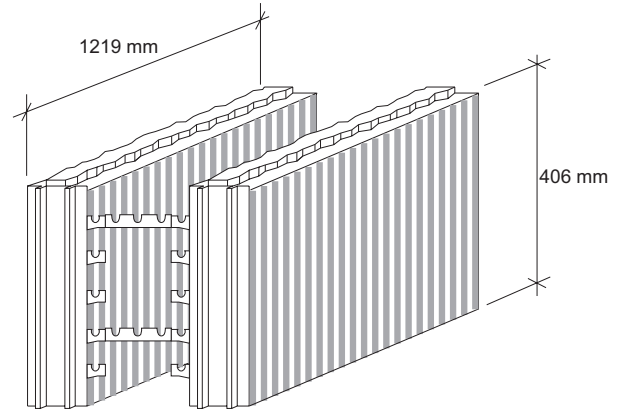

Figure 1. “ECO-Block®” Standard Units

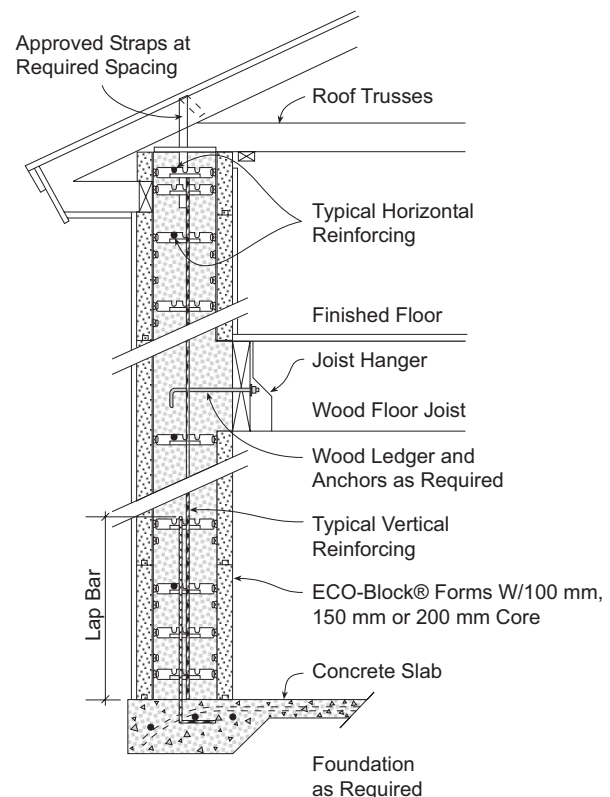
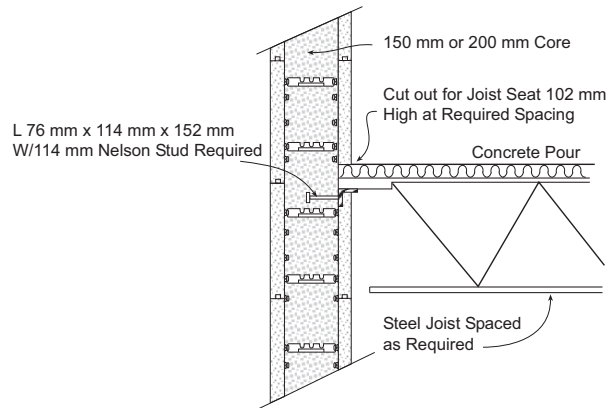
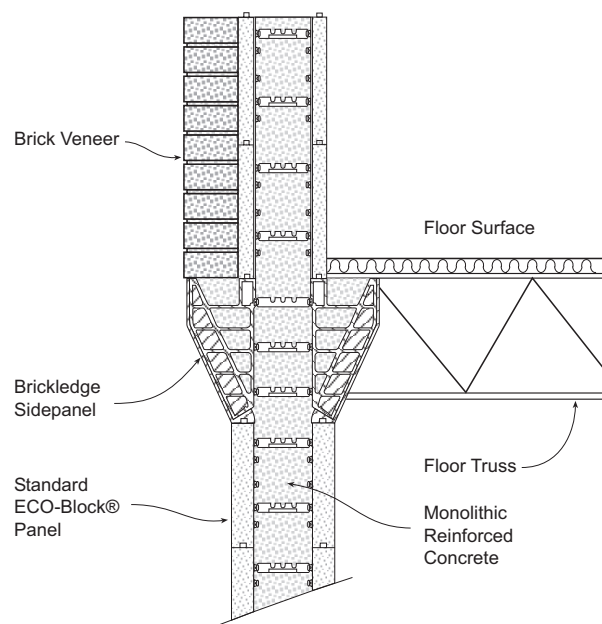

Figure 2. Typical Wall Section



**Figure 3. Typical detail for support of steel joist**



**Figure 4. Typical detail for support of brick veneer**

#### **4. Usage and Limitations**

The use of “ECO-Block®” is permitted in the construction of houses and small buildings, up to two storeys high, that fall under the provisions of Part 9 of NBC 1995, subject to the following conditions:

- The structural applications of “ECO-Block®” must be in strict accordance with the design

analysis prepared for ECO-Block® LLC, and presented in Report No. 990811.2, dated 21 August 2000, from which tables 1a, 1b, 2a, and 2b have been reproduced.

- The concrete used in “ECO-Block®” must be Type 10 or Type 30 and have a minimum compressive strength of 20 MPa and a maximum slump of 140±25 mm.
- For the wall heights indicated in tables 2a and 2b, the pouring of concrete must be made at a rate of 1.3 m/h in consecutive lifts; each lift is limited to a maximum height of 1.3 m.
- The EPS insulation used in this system must comply with CAN/ULC-S701-97, “Standard For Thermal Insulation, Polystyrene, Boards and Pipe Covering,” Type 2.
- “ECO-Block®” EPS insulation panels must be aged for not less than three weeks from the date of manufacturing.
- The interior face of “ECO-Block®” panels shall be protected from the inside of the building in accordance with Sentence 9.10.16.10.(1) of NBC 1995.
- For above-grade installations, the exterior face of “ECO-Block®” shall be protected with materials conforming to NBC 1995, Sections 9.20., 9.27. or 9.28.
- For foundation-wall installations, the backfill shall be placed in such a way as to avoid damaging the wall, the exterior insulation panel and the waterproofing and dampproofing protection.
- The concrete must be cured a minimum of seven days before backfilling. The top of the foundation wall must be supported by the first floor prior to backfilling.
- For below-grade installations, dampproofing material compatible with the EPS insulation must be provided in accordance with NBC 1995, Article 9.13.1.1.

Where hydrostatic pressure exists, waterproofing compatible with the EPS insulation must be provided in accordance with NBC 1995, Article 9.13.1.2.

- The backfill material must be well drained and a drainage system must be installed around the footing in accordance with NBC 1995.
- Installation of the “ECO-Block®” shall be in strict compliance with “ECO-Block® Installation Manual”, April 2003. Only installers who have been trained and authorized by “ECO-Block®, LLC” shall be contracted to set up the wall system.

## 5. Performance

Compliance of the expanded polystyrene thermal insulation with the requirements of CAN/ULC-S701-97 is covered under the Underwriters’ Laboratories of Canada Certificate and/or Label service.

The design analysis of walls using “ECO-Block®” as prepared for “ECO-Block®, LLC”, is summarized in tables 1a, 1b, 2a, 2b and 2c.

The tables provide steel reinforcement designs for different wall and lintel applications, based on the structural loads and on the design outlined below each table. When “ECO-Block®” is used in structural applications outside the scope of the referenced design analysis, a registered professional engineer skilled in concrete design must certify the design analysis and the design drawings for such buildings. The engineer shall certify that the construction provides a level of performance equivalent to that required by Part 4 and/or Part 9 of NBC 1995.

**Table 1a. Vertical/Horizontal Steel Reinforcement for Below-Grade Walls in all Seismic Zones<sup>(1)</sup>**

Wall Height (m)	Backfill Height (m)	Maximum Spacing of Vertical Reinforcement (mm)			Maximum Spacing of Horizontal Reinforcement (mm)		
		100 mm wall	150 mm wall	200 mm wall	100 mm wall	150 mm wall	200 mm wall
2.44	2.135	-(2)	15M @ 285	15M @ 300	-	15M @ 450	15M @ 495
	1.830	15M @ 300	15M @ 330	15M @ 370	15M @ 300	15M @ 450	15M @ 495
	1.525	15M @ 300	15M @ 330	15M @ 400	15M @ 300	15M @ 450	15M @ 495
	1.220	15M @ 300	15M @ 330	15M @ 550	15M @ 300	15M @ 450	15M @ 495
3.05	2.754	-	20M @ 165	15M @ 225	-	15M @ 450	15M @ 495
	2.440	-	15M @ 240	15M @ 265	-	15M @ 450	15M @ 495
	2.135	-	15M @ 285	15M @ 300	-	15M @ 450	15M @ 495
	1.830	-	15M @ 330	15M @ 370	-	15M @ 450	15M @ 495
	1.525	15M @ 300	15M @ 330	15M @ 450	15M @ 300	15M @ 450	15M @ 495
	1.220	15M @ 300	15M @ 330	15M @ 550	15M @ 300	15M @ 450	15M @ 495

**Table 1a. Vertical/Horizontal Steel Reinforcement for Below-Grade Walls in all Seismic Zones<sup>(1)</sup>**  
(cont'd)

Wall Height (m)	Backfill Height (m)	Maximum Spacing of Vertical Reinforcement (mm)			Maximum Spacing of Horizontal Reinforcement (mm)		
		100 mm wall	150 mm wall	200 mm wall	100 mm wall	150 mm wall	200 mm wall
3.66	3.355	-	-	15M @ 200	-	-	15M @ 495
	3.050	-	-	15M @ 270	-	-	15M @ 495
	2.745	-	-	15M @ 220	-	-	15M @ 495
	2.440	-	15M @ 240	15M @ 250	-	15M @ 450	15M @ 495
	2.135	-	15M @ 285	15M @ 300	-	15M @ 450	15M @ 495
	1.830	-	15M @ 330	15M @ 360	-	15M @ 450	15M @ 495
	1.525	15M @ 300	15M @ 330	15M @ 450	15M @ 300	15M @ 450	15M @ 495
	1.220	15M @ 300	15M @ 330	15M @ 550	15M @ 300	15M @ 450	15M @ 495

**Notes to Table 1:**

- (1) Table 1a is based on the following assumptions:
- Loads include earth pressure and surcharge loads, plus gravity load. Gravity load assumes 2 storeys and a wood-frame roof.
  - Wall height taken is 3.04 m and the snow load is equal to 1.9 kPa.
  - Applicable to all seismic zones.
  - Specified compressive strength of concrete  $f'_c$ , 20 MPa @ 28 days.
  - Specified yield strength of reinforcement  $f_y$ , 400 MPa.
  - Two #15 bars should be placed around all openings.
- (2) (-) means not feasible with respect to the proposed backfill height.

**Table 1b. Vertical/Horizontal Steel Reinforcement for Above-Grade Walls in all Seismic Zones<sup>(1)</sup>**

Wall Height (m)	Maximum Spacing of Vertical Reinforcement (mm)			Maximum Spacing of Horizontal Reinforcement (mm)		
	100 mm wall	150 mm wall	200 mm wall	100 mm wall	150 mm wall	200 mm wall
Single-storey concrete construction supporting a wood-frame roof structure						
2.44	15M @ 300	15M @ 450	15M @ 600	15M @ 300	15M @ 450	15M @ 495
3.05	15M @ 300	15M @ 450	15M @ 550	15M @ 300	15M @ 450	15M @ 495
3.66	15M @ 300	15M @ 450	15M @ 465	15M @ 300	15M @ 450	15M @ 495
Ground floor concrete construction supporting a second-storey wood-frame construction and a wood-frame roof structure						
2.44	15M @ 300	15M @ 450	15M @ 600	15M @ 300	15M @ 450	15M @ 495
3.05	15M @ 300	15M @ 450	15M @ 550	15M @ 300	15M @ 450	15M @ 495
3.66	15M @ 300	15M @ 450	15M @ 465	15M @ 300	15M @ 450	15M @ 495

**Table 1b. Vertical/Horizontal Steel Reinforcement for Above-Grade Walls in all Seismic Zones<sup>(1)</sup>  
(cont'd)**

Wall Height (m)	Maximum Spacing of Vertical Reinforcement (mm)			Maximum Spacing of Horizontal Reinforcement (mm)		
	100 mm wall	150 mm wall	200 mm wall	100 mm wall	150 mm wall	200 mm wall
Ground floor construction supporting a second-storey concrete construction and a wood-frame roof structure						
2.44	15M @ 300	15M @ 450	15M @ 600	15M @ 300	15M @ 450	15M @ 495
3.05	15M @ 300	15M @ 450	15M @ 550	15M @ 300	15M @ 450	15M @ 495
3.66	15M @ 300	15M @ 450	15M @ 465	15M @ 300	15M @ 450	15M @ 495

**Note to Table 1b:**

- <sup>(1)</sup> Table 1b is based on the following assumptions:
- Loads include all applicable gravity and wind loads.
  - Applicable to all seismic zones and to a maximum factored wind pressure of 3.15 kPa.
  - Specified compressive strength of concrete  $f_c$ , 20 MPa @ 28 days.
  - Specified yield strength of reinforcement  $f_y$ , 400 MPa.
  - Two #15 bars should be placed around all openings.

**Table 2a. Minimum Steel Reinforcement of Lintels with 100-mm “ECO-Block<sup>®</sup>” Forms<sup>(1)</sup>**

Opening Width (mm)	Factored Uniformly Distributed Load (kN/m)							
	2		5		10		15	
	Bottom Steel	Stirrup End Distance (mm)	Bottom Steel	Stirrup End Distance (mm)	Bottom Steel	Stirrup End Distance (mm)	Bottom Steel	Stirrup End Distance (mm)
1000	1 #10	0	1 #10	0	1 #10	0	1 #10	0
1500	1 #10	0	1 #10	0	1 #10	0		
2000	1 #10	0	1 #10	0				
2500	1 #10	0	1 #10	0				
3000	1 #10	0	1 #10	0				
3500	1 #10	0	1 #10	0				
4000	1 #10	0						
4500	1 #10	0						
5000	1 #10	0						

**Table 2b. Minimum Steel Reinforcement of Lintels with 150 mm “ECO-Block®” Forms<sup>(1)</sup>**

Opening Width (mm)	Factored Uniformly-Distributed Load (kN/m)													
	2		5		10		15		20		25		30	
	Bottom Steel	Stirrup End Dist. (mm)	Bottom Steel	Stirrup End Dist. (mm)	Bottom Steel	Stirrup End Dist. (mm)	Bottom Steel	Stirrup End Dist. (mm)	Bottom Steel	Stirrup End Dist. (mm)	Bottom Steel	Stirrup End Dist. (mm)	Bottom Steel	Stirrup End Dist. (mm)
1000	1 #15	0	1 #15	0	1 #15	0	1 #15	0	1 #15	0	1 #15	0	1 #15	40
1500	1 #15	0	1 #15	0	1 #15	0	1 #15	0	1 #15	60	1 #15	198	1 #15	290
2000	1 #15	0	1 #15	0	1 #15	0	1 #15	80	1 #15	310	1 #15	448	1 #15	540
2500	1 #15	0	1 #15	0	1 #15	0	1 #15	330	1 #15	560	1 #15	698	1 #20	790
3000	1 #15	0	1 #15	0	1 #15	119	1 #15	580	1 #15	810	1 #20	948	2 #15	1040
3500	1 #15	0	1 #15	0	1 #15	369	1 #20	830	1 #20	1060	2 #15	1198	1 #25	1290
4000	1 #15	0	1 #15	0	1 #15	619	1 #20	1080	1 #20	1310	1 #25	1448		
4500	1 #15	0	1 #15	0	1 #20	869	2 #15	1330	2 #15	1560				
5000	1 #15	0	1 #15	0	1 #20	1119	1 #25	1580	1 #25					

**Table 2c. Minimum Steel Reinforcement of Lintels with 200 mm “ECO-Block®” Forms<sup>(1)</sup>**

Opening Width (mm)	Factored Uniformly-Distributed Load (kN/m)													
	2		5		10		15		20		25		30	
	Bottom Steel	Stirrup End Dist. (mm)	Bottom Steel	Stirrup End Dist. (mm)	Bottom Steel	Stirrup End Dist. (mm)	Bottom Steel	Stirrup End Dist. (mm)	Bottom Steel	Stirrup End Dist. (mm)	Bottom Steel	Stirrup End Dist. (mm)	Bottom Steel	Stirrup End Dist. (mm)
1000	1 #15	0	1 #15	0	1 #15	0	1 #15	0	1 #15	0	1 #15	0	1 #15	0
1500	1 #15	0	1 #15	0	1 #15	0	1 #15	0	1 #15	0	1 #15	16	1 #15	138
2000	1 #15	0	1 #15	0	1 #15	0	1 #15	0	1 #15	83	1 #15	266	1 #15	388
2500	1 #15	0	1 #15	0	1 #15	0	1 #15	27	1 #15	333	1 #15	516	1 #20	638
3000	1 #15	0	1 #15	0	1 #15	0	1 #15	277	1 #15	583	1 #15	766	2 #15	888
3500	1 #15	0	1 #15	0	1 #15	0	1 #15	527	1 #15	833	1 #20	1016	1 #25	1138
4000	1 #15	0	1 #15	0	1 #15	165	1 #15	777	1 #20	1083	1 #25	1266	2 #20	1388
4500	1 #15	0	1 #15	0	1 #20	415	2 #15	1027	2 #15	1333	1 #30	1516	2 #25	1638
5000	1 #15	0	1 #15	0	1 #20	665	1 #25	1277	1 #30	1583	2 #25	1766	2 #25	1888



---

**Note to tables 2a, 2b and 2c:**

- (1) Tables 2a, 2b and 2c are based on the following assumptions:
- The factored uniformly-distributed load includes live and dead loads.
  - The minimum height of the lintel is 406 mm.
  - Stirrups are single leg, fabricated from #10 bars spaced at 170 mm on centre.
  - Lintel reinforcement is located in bottom of lintel and projects 205 mm into the lintel support on each side.
  - Specified compressive strength of concrete  $f'_c$ , 20 MPa @ 28 days.

For more information contact:

Fadi Nabhan  
(613) 993-7702

*Issued by the Institute for Research in Construction  
under the authority of the National Research Council*

John Flack, Ph.D.  
Manager, CCMC

*Note: Readers are asked to refer to limitations imposed by NRC on the interpretation and use of this report. These limitations are included in the introduction to CCMC's Registry of Product Evaluations, of which this report is part.*

*Readers are advised to confirm that this report has not been withdrawn or superseded by a later issue by referring to <http://irc.nrc.gc.ca/ccmc>, or contacting the Canadian Construction Materials Centre, Institute for Research in Construction, National Research Council of Canada, Montreal Road, Ottawa, Ontario, K1A 0R6; Telephone (613) 993-6189, Fax (613) 952-0268.*